





**VLUCHT EN KAPACITEIT
RADIUS AND S.W.L.
PORTEE ET CHARGE
AUSLADUNG UND TRAGFAHIGKEIT**

Max. Kap. Max. s.w.l. Charge max. /Max. Tragfähigkeit		3000 Kg. 			5000 kg.   / 2500 Kg. 		
Giek/Radius m. Ausladung/Portée m.		30	36	42	30	36	42
Max. Kap. van tot Max. s.w.l. range from to Charge maxi de à Max. Tragfähigkeit von bis		25,5	23,2	20,7	15,9	14,5	13,1
	12	3000	3000	3000	5000	5000	5000
	14	3000	3000	3000	5000	5000	5000
	16	3000	3000	3000	4890	4480	3960
	18	3000	3000	3000	4360	3910	3460
	20	3000	3000	3000	3860	3460	3050
Vlucht (m.)	22	3000	3000	2790	3460	3100	2730
Radius (m.)	24	3000	2880	2460	3130	2800	2460
Portée (m.)	26	2940	2630	2310	2850	2540	2230
Ausladung (m.)	28	2690	2400	2110	2610	2320	2030
	30	2500	2230	1850	2400	2140	1870
	32		2060	1815		1970	1720
	34		1920	1680		1830	1590
	36		1800	1570		1700	1480
	38			1470			1370
	40			1380			1280
	42			1300			1200

**GIEK EN GIEKBALLAST
JIB AND COUNTERWEIGHT
FLECHE ET CONTREPOIDS
AUSLEGER UND GEGENGEWICHTSBALLAST**

Giek / Jib (m.) Flèche / Ausleger (m.)		30	36	42
Giekbballast / Counterweight (t.) Contrepoids / Gegengewicht (t.)		5,800	7,250	8,700
Samenstelling Composition Komposition	Type	Aantal / Quantité / Nombre / Anzahl		
	A60	4	5	6

**HAAKHOOGTE, MAX. BASISBALLAST EN HOEKDRUK
H.U.H., MAX. BASE BALLAST AND CORNER PRESSURE
H.S.C., LEST DE BASE MAXI ET REACTIONS
HAKENHOHEN, MAXIMALE ZENTRALBALLASTE UND ECKDRUCK**

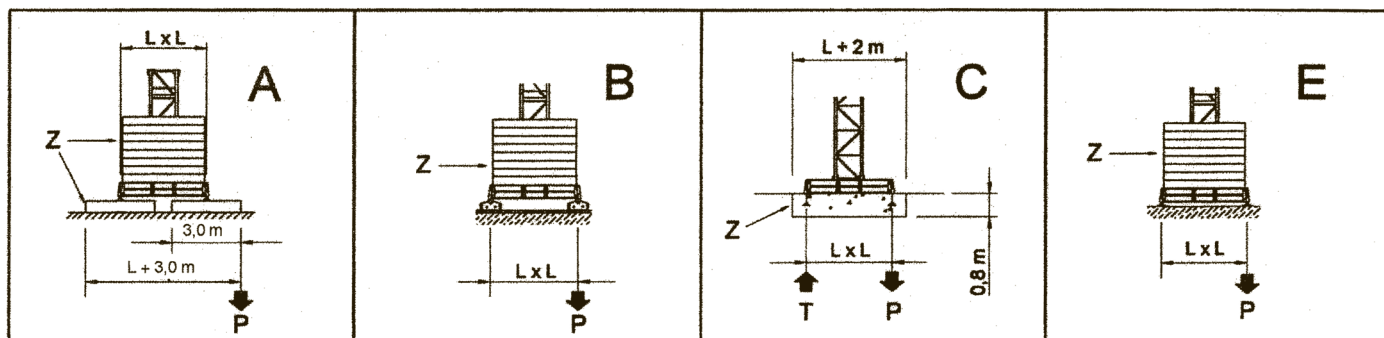

**OP CHASSIS / ON CROSSBASE
SUR CHASSIS / AUF KREUZRAHMEN**

L = 3,2 m

A			B			C				E		
H	max.Z	P	H	max.Z	P	H	max. Z	T	P	H	max.Z	P
(m)	(t)	(kN)	(m)	(t)	(kN)	(m)	(t)	(kN)	(kN)	(m)	(t)	(kN)
12,5	50,25	285	12,2	50,25	285	11,8	CF*	70	177	12,3	52,25	285
18,5	50,25	324	18,2	50,25	324	17,8		78	194	18,2	52,25	324
24,5	50,25	341	24,2	50,25	340	23,8		88	209	24,1	52,25	341
30,5	50,25	360	30,2	50,25	359	29,8		99	227	30,0	52,25	360
36,5	60,35	417	36,2	60,35	416	35,8		144	285	35,9	62,55	417

CF*: CONSULT FACTORY

**OP INSTORTVOET / STATIONARY
SUR PIEDS DE SCELLEMENT / STATIONAR AUF FUNDAMENTANKER**

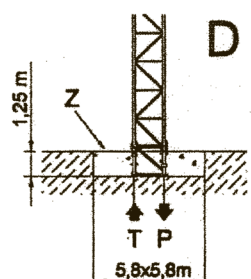

H(m)	11,4	17,4	23,4	29,4	35,4
T (kN)	321	345	377	416	557
P (kN)	415	452	491	535	687

